

## HS-502A-HD Technical Data Sheet

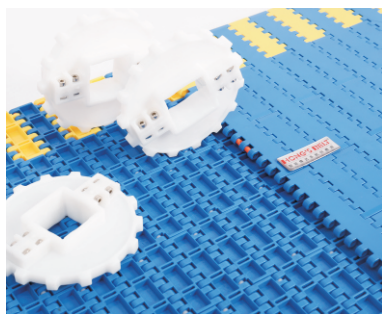
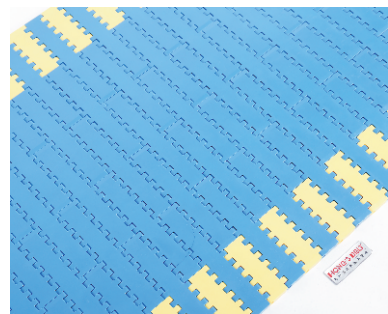
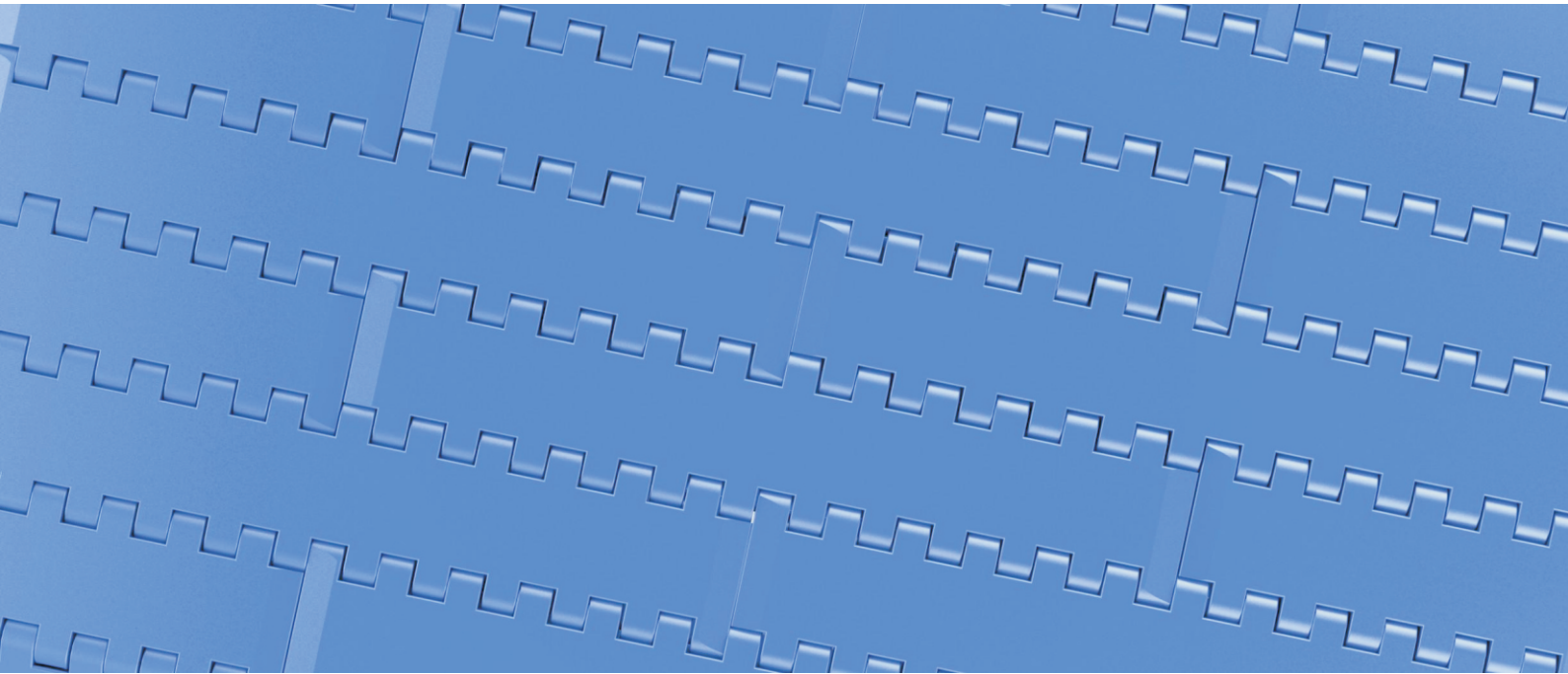

<p>Pitch: 25.4mm                  Minimum Width: 76mm                  Open Area: 0%                  Approved: FDA                  Rod: Ø 4.9mm                  Flight: Yes                  Side Guard: No                  Curve: No</p>	
---	--

### Data

Belt Material	Belt Strength			Temperature		Belt Weight (Kg/M <sup>2</sup> )
	Straight		Curve	°C (min.)	°C (max.)	
	Kg/M(BW)	N/M(BW)		°C (min.)	°C (max.)	
Polypropylene	2000	20000	--	1	100	5.4
Acetal	3500	35000	--	-40	80	8.3
HK	3500	35000	--	-40	80	7.9

BW – Belt Width

### Color Table

Polypropylene					Polyethylene					Acetal					Nylon				
W	G	N	DB	B	W	G	N	DB	B	W	G	N	DB	B	W	G	N	DB	B
●	●			●						●				●					

W-White, G-Gray, N-Nature, DB-Dark brown, B-Blue (For more information of belt color, pls consult our sales team)

### Friction Table

Belt Material	Friction Wear strips & Products							
	UHMW	HDPE	Steel	Glass	SUS	Plastic	Cardboard	Aluminum
Polypropylene	0.32	0.24	0.15	0.09	0.13	0.08	0.15	0.25
Polyethylene	0.13	0.11	0.26	0.19	0.31	0.16	0.21	0.41
Acetal	0.11	0.09	0.27	0.16	0.26	0.15	0.19	0.28
Nylon	0.18	0.13	0.25	0.16	0.26	0.16	0.19	0.27

SUS – Stainless Steel

### Equivalent type with other Brand

Brand Name	Intralox	Habasit	UNI	Rexnord	MCC	ScanBelt
Series & Type	--	--	QNB C	--	--	--

The above content is only for reference.

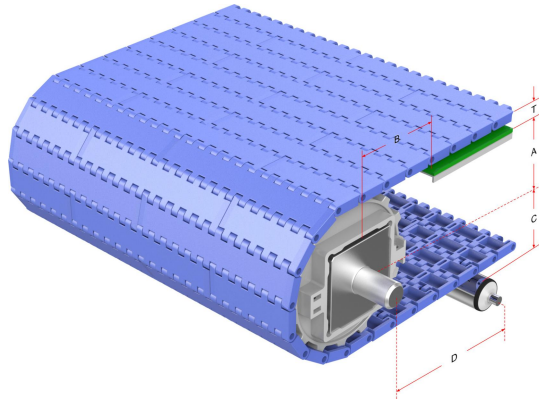

## Conveyor Frame Dimensions

Unit : mm

No. Teeth	A ( Min.)	B ( Min.)	C ( Max.)	D ( Min.)	T
10	35.6	50	35.2	200	8.8
12 / 12-Split	43.95	58.35	43.55	200	
15 / 15-Split	56.25	70.65	55.85	200	
18 / 18-Split	68.6	83	68.2	200	
19-Split	72.85	87.25	72.45	200	
24-Split	92.6	107	92.2	250	

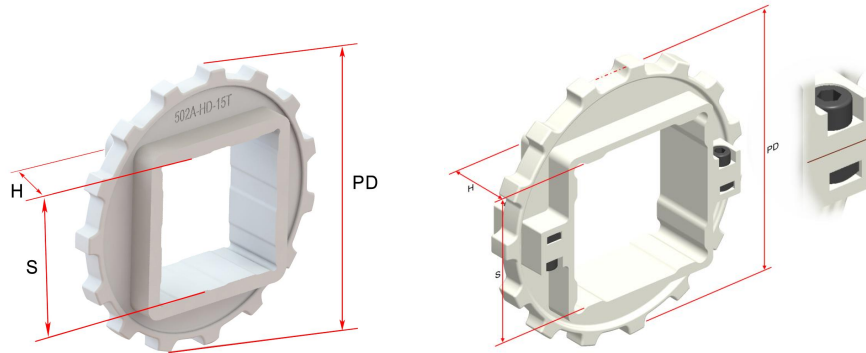

## Sprocket Dimensions

Unit: mm

No. Teeth	PD	OD	S	D	H	K
10	82.20	80	38.1/40	25/25.4	25	8X8
12	98.14	96.7	38.1/40	25.4/30/38.1/40	25	8X8
12-Split	98.14	96.7	38.1/40	38.1	25	9.52X4.76
15	122.17	121.3	38.1/40/50/60/63.5	25.4/35/40/50	29.5	8X8
15-Split	122.17	121.3	38.1/40/50/60/63.5/65	--	33	--
18	146.27	146	38.1/40/45/50/60/63.5/64	25.4/30/50	25	8X8
18-Split	146.27	146	38.1/40/60/63.5	50.8	35	14X5
19-Split	154.32	154.5	38.1/40/50/50.8/60/65	--	35	--
24-Split	194.60	194	60/65	--	52	--